

Operating Instructions

DPG 101

***Vacuum Measurement And
Control Gauge***

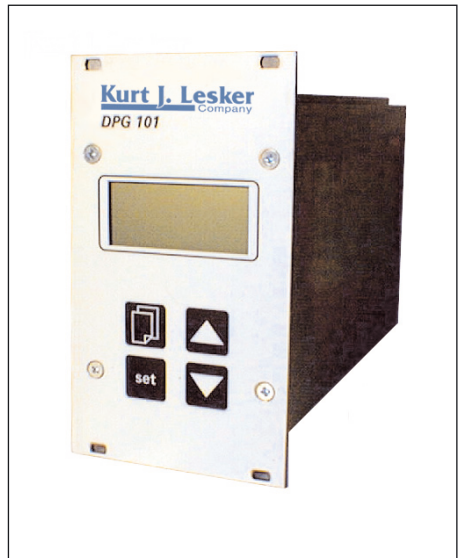

Index

	Page
1. Safety Instructions	3
1.1. For Your Orientation	4
2. Understanding The DPG 101	5
2.1. Main Features	5
Proper Use	6
Improper Use	6
2.2. Package Contents	6
3. Installation	7
3.1. Preparation For Installation	7
3.2. Mains Connection	8
3.3. Transmitter Connection	8
3.4. Analog Output	0
3.5. Relay Output	10
4. Operation	11
4.1. First Time Starting	11
4.2. Switching On The Unit	11
4.3. Measuring Mode	12
4.4. Configuration Mode	12
4.4.1. Setting The Threshold And Hysteresis Values	12
4.4.2. Setting The Gas Type And Correction Factor	14
4.4.3. Selecting The Unit Of Measurement	15
4.4.4. Retro-Adjustment	15
4.4.5. Degassing Function	17
5. Error Signals	18
6. Maintenance, Service	19
7. Technical Data	20
7.1. Data Lists	20
7.2. Dimensions	21
8. Accessories	22
9. Supplementary Information	23

Please note!

Current operating instructions are available at www.Lesker.com

1. Safety Instructions

- ☞ Read and follow all the instructions in this manual.
- ☞ Inform yourself regarding:
 - Dangers which can be caused by the unit
 - Dangers which can be caused by the system
- ☞ Observe the safety and accident prevention instructions.
- ☞ Check regularly that the safety procedures are being complied with.
- ☞ Take into account the prevailing environmental conditions when installing the DPG 101.
- ☞ The protection type is IP 20.
- ☞ Take account of the relevant instructions when handling the process media and observe the safety procedures.
- ☞ Take account of the possible reactions between materials and process media.
- ☞ Take account of possible reactions in the process media resulting from the spontaneous warming of the product.
- ☞ Do not carry out any unauthorized modifications to or conversions on the unit.
- ☞ When returning the unit to the manufacturer please follow the shipping instructions.
- ☞ Before beginning work, inform yourself regarding the existence of any possible contamination.
- ☞ When handling contaminated parts observe the relevant instructions and follow the safety procedures.
- ☞ Ensure that all other users receive the safety instructions.

Validity

These operating instructions describe the installation and operation of the Digital Vacuum Measurement And Control Unit DPG 101 with the part number KTG10010. The part number appears on the rating plate.

To ensure the avoidance of possible product identification errors in any correspondence with the Kurt J. Lesker Company please always state the part number appearing on the rating plate.

This document is based on the component software version 1.40.

Technical modifications reserved

1.1. For Your Orientation

Abbreviations used:

CPT = Compact Ceramic Transmitter
RPT = Resistive Piezo Pirani Transmitter
PPT = Pirani Pressure Transmitter
HPT = Hot Cathode Pirani Transmitter
DPG = Digital Pressure Gauge
DPS = Digital Power Supply

Working instructions in the text,

➔ Here you have to do something.

Pictogram Definitions



Danger of an electric shock.



Danger of personal injury.



Danger of damage to the pump or system.



Important Note.

2. Understanding The DPG 101

2.1. Main Features

Front Panel, DPG 101

- 1 Display for measured pressure value
 - Switch thresholds (S1, S2),
 - Hysteresis,
 - Units of measurement (mbar, bar, mTorr, Torr, hPa, Pa)
- 2 Menu key
- 3 Set key
- 4 Up/Down keys



Product Identification on the rating plate

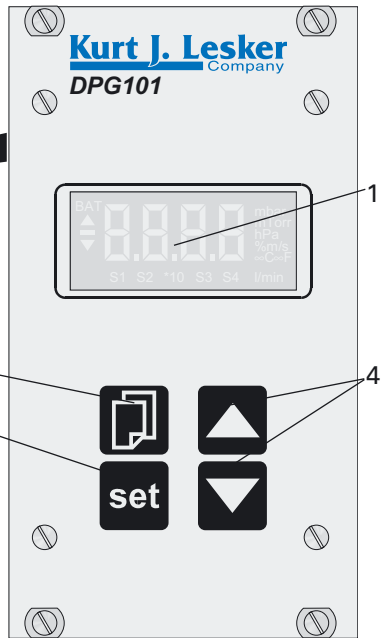

Connections Side, DPG 101

- 5 Component fuse, 0,8 AT
- 6 Mains switch
- 7 Mains connection
- 8 Analog output
- 9 Transmitter input
- 10 Relay contacts

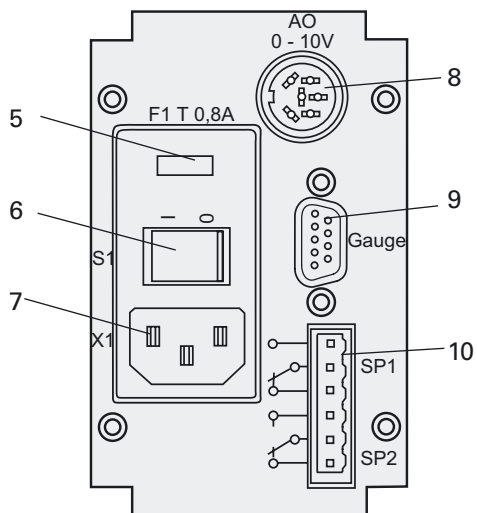

Proper Use

The DPG 101 serves, in conjunction with DigiLine Vacuum Transmitters of the Kurt J. Lesker Company, to measure and control total pressures. The unit is ready for connection to transmitters of types CPT 100, RPT 100, PPT 100 and HPT 100.

All products used in this connection must be operated in accordance with their operating instructions.

Connect only original accessories of the Kurt J. Lesker Company.

Improper Use

The following is regarded as improper:

- The use for purposes not covered above, in particular:
- the connection to components which is not permitted according to their operating instructions;
- the connection to components which contain touchable, voltage carrying parts.

No liability will be accepted for claims arising from improper use.

The user bears the responsibility with respect to the process media.

2.2. The Delivery Content

The following items are included in the package:

- DPG 101 KTG10010
- Mains cable
- Mating plug for the relay and recorder output
- Operating Instructions PG0006KJL.

3. Installation

3.1. Preparations For Installation



Do not carry out any unauthorized modifications to or conversions on the unit. Before connecting to local mains power: The voltage stated on the rating plate of the DPG 101 must correspond with the local mains values. The DPG 101 contains a multi voltage mains power pack with an input voltage range of 90 ... 264 V.

Only use this controller where the:

- Temperature is in the range: +5°C - +40°C (+ 41°F ... +100 °F).
- Relative humidity is in the range: 5 - 85%, non-condensing.
- Atmospheric pressure is in the range: 86 kPa - 106 kPa (12.5 psi - 15.4 psi)



Only electro-technically trained personnel should effect and adapt cabling. Connect only appropriate original accessories of the Kurt J. Lesker Company. Take account of the technical data to avoid overloading (which can cause danger for the operator and damage to the unit).

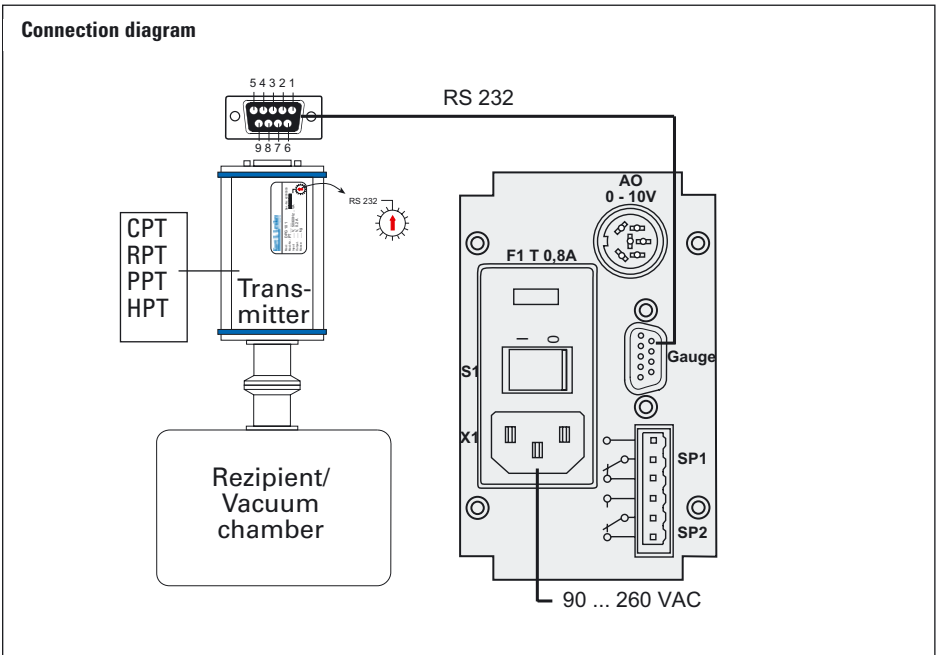

3.2 Mains Connection



The mains plug may only be plugged into a socket with protective contacts. Use only 3 pole mains cable with proper protective earth connection. The protective earthing may not be replaced by an extension lead without protective earthing. The mains cable should be connected before all other cables in order to ensure continuous earthing.

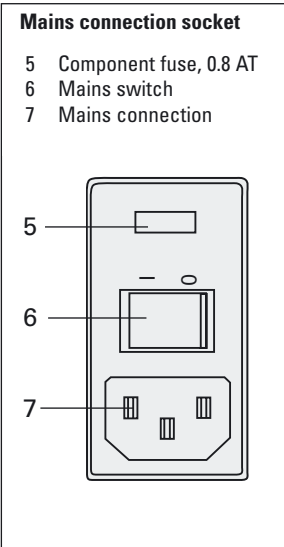

If the unit is fitted into a rack, mains voltage must be supplied via a switched mains distributor.

3.3 Transmitter Connection



The display unit must be in switched off condition when a transmitter is connected. Non observance of this instruction can lead to damage to the component.



When connecting the transmitter to the DPG 101, set the address switch on the rating plate of the transmitter to the position "RS 232" (factory setting).

Transmitter Connection

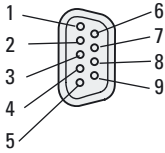

Sub D socket, 9 pole (female)

Pin 1, 4, 7, 8, 9: n.c.
Pin 2: RS232, RxD
Pin 3: RS232, TxD
Pin 5: GND
Pin 6: VCC

3.4 Analog Output

This connection provides an analog measurement signal which delineates the measurement range of the respective connected total pressure transmitter to the range 0 - 10 VDC: Loading capacity $\geq 10 \text{ k}\Omega$.

Analog output

Pin 2: 0 - 10 V
Pin 6: GND



Amphenol C91E socket, 6 pole

CPT 100: linear;
other: logarithmic, in accordance with the following formula:

$$\text{Output (V)} = \frac{10 \text{ V}}{\text{DECADES}} \bullet (\log p [\text{mbar}] - \text{EXP0})$$

Example: Measuring range PPT 100 = $1 \bullet 10^{-4} \dots 1000 \text{ mbar}$;
DECADES = 7; EXP0 = -4;

Actual pressure = $5 \bullet 10^1 \text{ mbar}$: Output = 5.28 V.

DECADES: Number of marked decades from the measuring range.

EXP0: Exponent of the lower measuring range limit in mbar.

p: Current pressure in mbar.



The analog output for the **RPT 100** transmitter is limited:

$1 \bullet 10^{-4} \text{ mbar} \dots 1000 \text{ mbar} \hat{=} 0 \dots 10 \text{ V}$.

3.5 Relay Output

Use this output for the external control of the switching functions of the DPG 101. For this, two relay switchpoints are available.



Use the mating plug provided.
Connect and disconnect the plug only in voltage free condition.
Load the outputs only with a maximum of 2A.

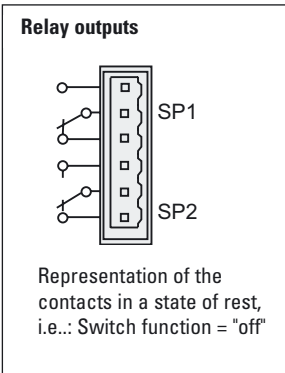

Phoenix Combicon, 6 pole (male)

4. Operations

4.1. First Time Starting



Before switching on it is important to ensure that the operating voltage selected on the unit corresponds with the local mains voltage and that the protective earth is in place.

Test the earthing of the unit and correct installation of all connecting lines and the transmitter.



The connected transmitter requires a warm up phase of at least 5 minutes. Do not subject the transmitter to any large fluctuations in pressure before equalization.

4.2. Switching On The Unit

The mains switch is located on the back panel of the unit (please see Section 2.1).

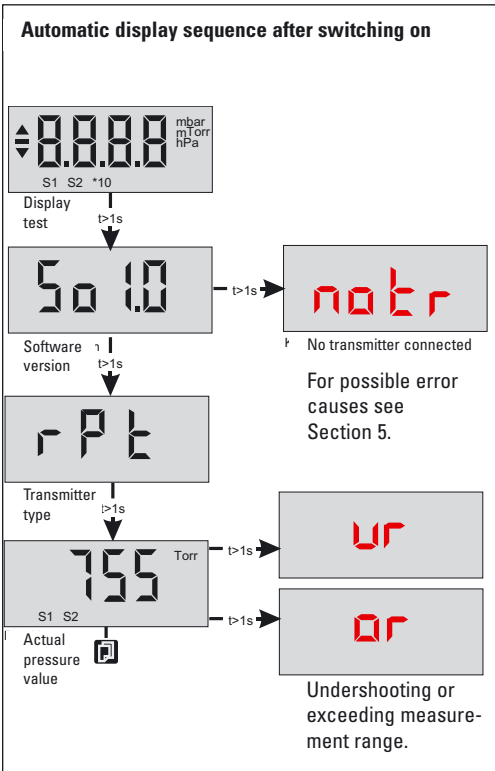

The unit carries out a self test and the following display sequence appears automatically:

- Software version number.
- Before last switching off the actual parameters are actualized.
- The unit identifies automatically the connected total pressure transmitter and the corresponding type appears in the display.
- The DPG 101 switches into measuring mode; the actual pressure value appears in the display.

4.3. Measuring Mode

In measuring mode the DPG 101 shows the pressure of the connected transmitter currently being measured. The display appears, depending on the measurement range, either numerically or exponentially.

The switch outputs are controlled in accordance with the set switch parameters and actual pressure.

Communication with the transmitter has been disrupted if the pressure display flashes or a flashing type appears in the display.

➔ In this case re-initialize the unit by depressing the menu key .

4.4. Configuration Mode

The DPG 101 configuration mode is attained via the menu key. There, the parameter switchpoints S1/S2, hysteresis H1/H2 can be set successively; for further parameters please refer to the following sections up to 4.4.5..

4.4.1 Setting The Threshold And Hysteresis Values

The two switchpoints S1 and S2 on the DPG 101 are controlled via a threshold value with pertinent hysteresis H1 and H2, as depicted in the illustration.

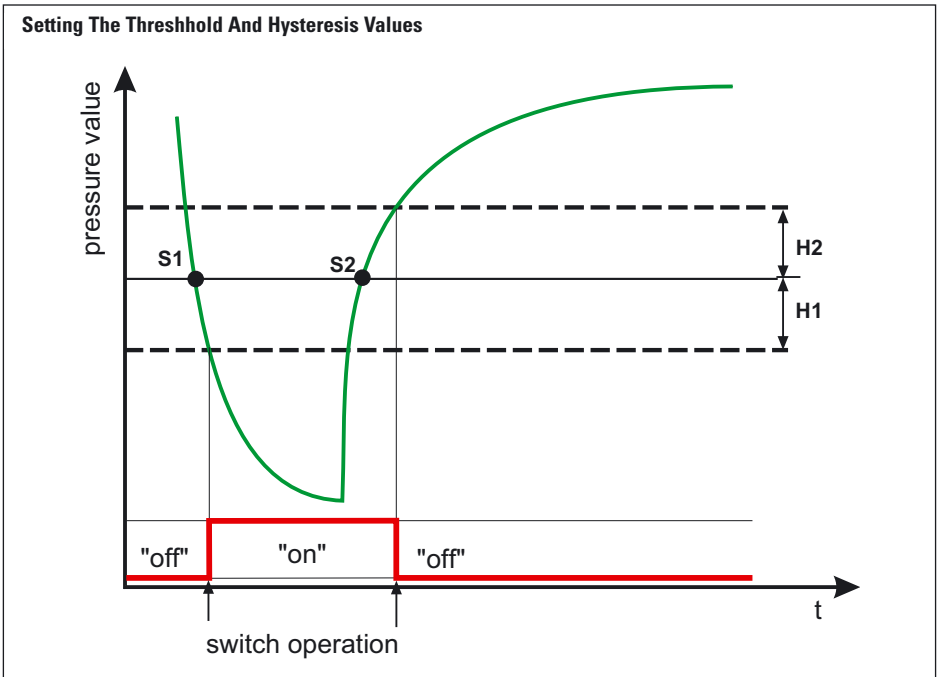

Setting the threshold and hysteresis values

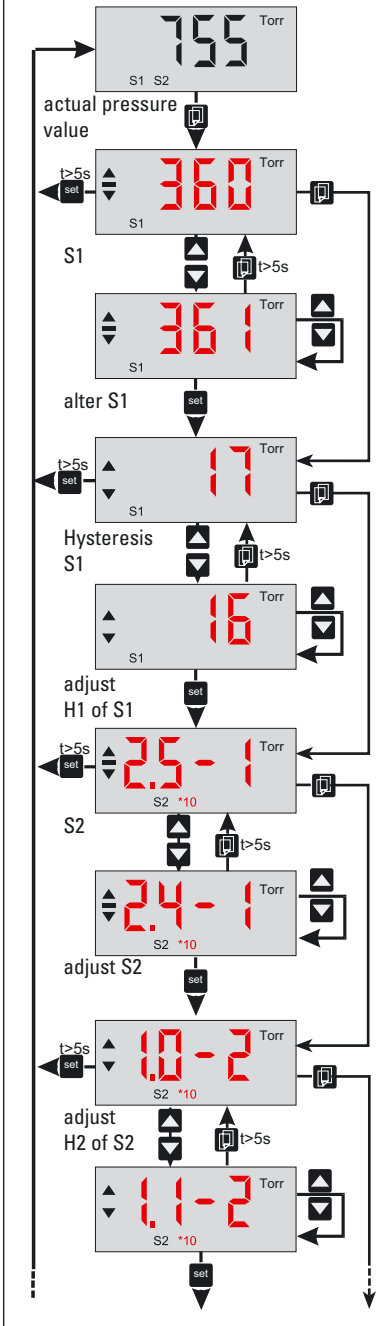

⇒ Select switchpoint S1 with the menu key. If the key is not further depressed for approximately 5 seconds the unit returns to measuring mode.

- ⇒ Change to the required value for switchpoint S1 with the Up/Down keys.
- ⇒ The altered switchpoint value is accepted by depressing the set key and the display shows the next parameter (hysteresis of S1).

If no further key is depressed for five seconds or after activating the menu key, the altered value is rejected and the original value is displayed ("Undo" function).

- ⇒ Proceed in the same way for the parameters:
 - Hysteresis H1, Switchpoint S2, Hysteresis H2.



The hysteresis is symmetric to the switchpoint. By altering the switchpoint the pertinent hysteresis is first matched automatically to the new threshold value via a percental correlation.

Example:

Old setting:

SP1 ==> 20 mbar

Hysteresis ==> 2 mbar (= 10%),

i.e. switch-off point 18 mbar,
switch-on point 22 mbar.

new threshold value:

SP1 ==> 400 mbar

new hysteresis ==> 40 mbar.

4.4.2 Setting The Gas Type Correction Factor



On total pressure transmitters which employ a gas dependent measuring method a correction factor can be assigned to the transmitter for the purpose of adaptation to the various gases. This ensures that in a broad range of pressures the correct pressure is displayed. Where combined gauge heads with differing physical measurement methods are involved, two correction factors are currently required (please see the operating instructions for the transmitter).

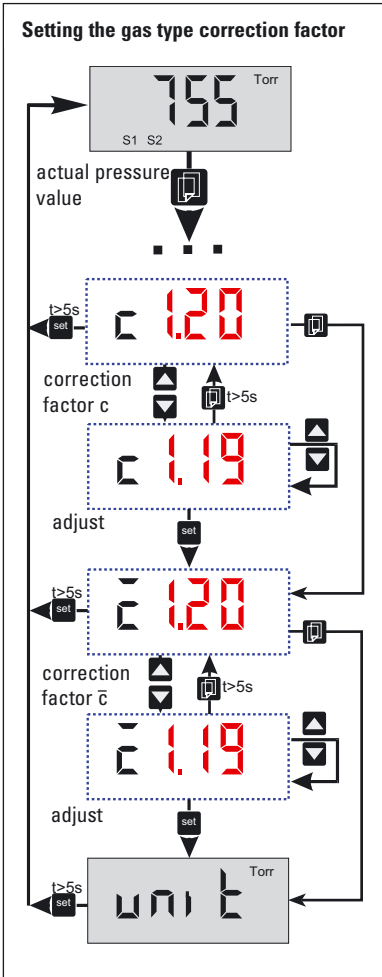

➔ Select **correction factor c** with the menu key; keep the key depressed until the three digit value of the correction factor appears in the display.

After releasing the key for approximately 5 seconds the unit returns to the measuring mode.

➔ Change the **correction factor c** to the required value using the Up/Down keys.

➔ After depressing the set key the new value is transmitted to the transmitter and accepted and the next parameter (for HPT transmitter: **correction factor \bar{c}**) appears in the display:

- **Correction factor c**: valid for "Pirani part" of HPT transmitter.
- **Correction factor \bar{c}** : valid for "Bayard-Alpert part" of HPT transmitter.

If the key is not further depressed for five seconds or after activating the menu key, the altered value is rejected and the original value is displayed.



Displays depicted in shaded form in this operating instructions are not, depending on the type of transmitter, represented and are skipped in the menu sequence.

4.4.3 Selecting The Unit Of Measurement

The unit of measurement for the pressure display is superimposed on the right-hand edge of the display. The following units can be selected: **mbar, bar, Pa, hPa, mTorr, Torr.**

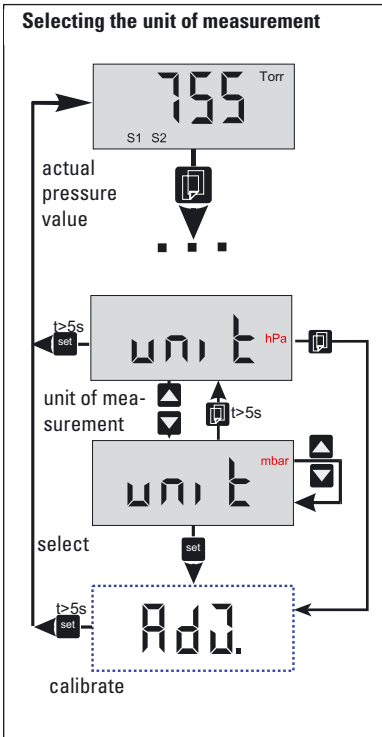

- ➔ Select the **unit of measurement** with the menu key; keep the key depressed until «unit» appears in the display. After releasing the key for approximately 5 seconds the unit returns to the measuring mode.
- ➔ Change to the required **unit of measurement** with the Up/Down keys.
- ➔ After depressing the set key the new value is accepted and the display moves to the next parameter («Adj.»).

If the key is not further depressed for five seconds or after activating the menu key, the altered value is rejected and the original value is displayed.

4.4.4 Retro-Adjustment

Retro-adjustment of the connected transmitter can be effected with the help of the DPG 101.



The connected transmitter requires a warm-up phase of at least 5 minutes. Do not subject the transmitter to any large fluctuations in pressure before equalization. Before zero point equalization ensure that the pressure in the vacuum chamber is at least one decade below the measurement range limit of the transmitter.

Automatic alignment of the HPT 100 in the "ur" range (under range)

Starting with instrument version 010500 of the HPT 100, the alignment is run automatically while simultaneously the following conditions apply:

- the pressure of the Bayard-Alpert component is $<5,0 \cdot 10^{-5}$ mbar.
- the measured value of the Pirani component does not change for one minute and does deviate too much from the most recent calibration value.

4.4.5 Degassing Function

With total pressure transmitters employing the hot cathode measuring system, for example of the Type HPT 100, it may be necessary to bake out the anode of the sensor in ultra high vacuum to remove adsorbed gas particles and therefore minimize gauge head degassification.

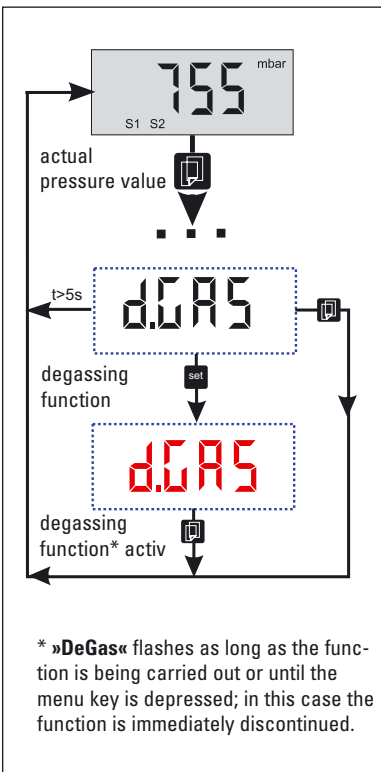

- ➔ Activate the degassing function by keeping the menu key depressed until **«d.GAS»** appears in the display.

After releasing the key for approximately 5 seconds the unit returns to the measuring mode.

- ➔ Start the degassing procedure with the set key.

The degassing procedure lasts approximately 3 minutes. No measurements are possible during this period; **«d.GAS»** flashes in the display. After this, the unit returns to the measuring mode. The degassing procedure can be interrupted at any time by activating the menu key.

5. Error Signal

Error	Possible Cause	Elimination
No display	<ul style="list-style-type: none"> • mains cable disrupted • Mains voltage absent or too high/too low 	Check mains cable Check mains voltage
The DPG 101 has not been able to communicate with a transmitter Display: «notr»	<ul style="list-style-type: none"> • No transmitter is connected • The address selection switch on the transmitter has not been set on RS 232. • The connected transmitter or the unit serial interface of the DPG 101 is defective. • The data line between the DPG 101 and the transmitter is not correctly connected and/or defective 	
Display: «ur/or»:	<ul style="list-style-type: none"> • The measured pressure is outside the measuring range of the transmitter. 	
Display: «Err1»	<p>The connected transmitter is defective.</p> <div data-bbox="378 612 463 719" style="border: 1px solid black; padding: 5px; display: inline-block;"> <p style="font-size: 8px; margin: 0;">PLEASE NOTE</p>  </div> <p>If the error «Err1» occurs because of defective filaments of the Bayard Alpert sensor of the HPT, the display indicates «ur» temporarily. Then «Err1» is displayed.</p>	<p>Reset error message by switching mains switch Off/On. The Pirani sensor is then functioning again.</p>

6. Maintenance, Service

The unit requires no maintenance. Any dirt can be removed using a moist cloth while ensuring that the unit is disconnected from the voltage supply.

Please do make use of our servicing facilities.

Should damage occur to the DPG 101 Vacuum Measuring And Control Unit, there are various options available in order to minimize any possible system down times:

- Return the unit to the manufacturer for repairs;
- Exchange for a new value unit.



The unit cannot be field serviced.



Please note that where units are returned for repair or maintenance, work is carried out subject to our general conditions of sale and supply.



Units which are returned for repair should be as free as possible from contamination (for example radioactive, toxic, caustic or microbiological).

- ➔ Take account of the shipping requirements in the countries involved.
- ➔ Include the completed declaration of contamination.

Where components are not clearly marked as "Free of contamination" the cost of any decontamination work will be billed to the customer.

7. Technical Data

7.1. Data Lists

Display:	numeric LCD-Display, background illuminated, 4 digits, 45 x 20 mm (1.8 x 0.8 inch) Measurement value: >10mbar: 4 digits / 10>p>1mbar: 2 digit, one place after the comma <1mbar: 2 digit mantissa, 1 digit exponent with preceding sign Measurement unit: mbar, bar, Pa, hPa, mTorr, Torr Switchpoints: SP1, SP2
Keyboard:	4 mechanical keys under the front foil: Menu, Set, Up, Down
Voltage supply:	90 ... 264 VAC; 50/60Hz
Power consumption:	ca. 15 W (without transmitter)
Fuse:	0.8 A T
Scanning rate:	25 Hz
Display rate:	2 Hz
Operating temperature:	+5 °C ... +50 °C (-4 °F ... +140 °F)
Storage temperature:	-20 °C ... +60 °C (+ 41 °F ... +104 °F)
Switchpoints:	2x polarized relay (Phoenix Combicon, male, 6 pole) Response time < 50 ms Life time > 100000 cycles
Switching power:	2 A, 260 VAC 2 A, 50 VDC
Transmitter supply:	24 VDC
Transmitter connection:	RS 232 (Sub D socket, 9 pole)
Output:	Analog output, 0 - 10 V (Amphenol, socket, 6 pole) Loading capacity $\geq 10 \text{ k}\Omega$
Dimensions:	19"-Insert, 14TE/3HE, 71 x 128 x 178 mm (2.8 x 5.0 x 7.0 inch)
Weight:	690 g (1.5 lbs)

7.2. Dimensions

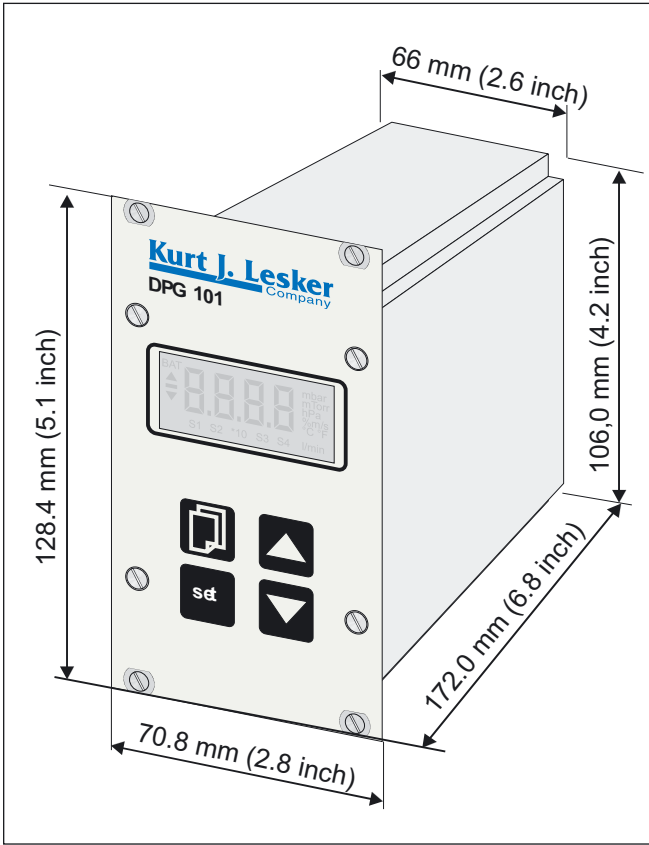

8. Accessories

Description	Size	Units	Number	Comments
CPT 100 Rough Vacuum Transmitter	DN 16 ISO-KF		KTR31130	
RPT 100 Combi Vacuum Transmitter	DN 16 ISO-KF DN 16 CF-F		KTR32130 KTR32330	
PPT 100 Medium Vacuum Transmitter	DN 16 ISO-KF DN 16 CF-F		KTR33130 KTR33330	
HPT 100 High Vacuum Transmitter	DN 40 ISO-KF DN 40 CF-F		KTR34130 KTR34330	
Transmitter connection cable for connection to DPG 101 Controller (RS 232)	3m	1	KT348203T	
TIC 002 Level converter		1	KT051519AT	
Software "Dokustar "		1	KT882500	
Software "Dokustar Plus"		1	KT882501	

9. Supplementary Information

Depending on the configuration of your components further operating instructions are included in the package (please see the table). If, despite every effort by us, information on your products is missing please get in touch with your local Kurt J. Lesker Company representative or contact us using the information shown on the back cover page.

The following operating instructions are available for digital transmitters and accessories:

Product	Definition	Operating Instructions Nr.
CPT 100	Rough Vacuum Transmitter	PG0001KJL
PPT 100	Medium Vacuum Transmitter	PG0002KJL
RPT 100	Combination Vacuum transmitter	PG0003KJL
HPT 100	High Vacuum transmitter	PG0004KJL
DPG 101	Display Unit	PG0006KJL
DPS 101	Switching Power Pack	PG0007KJL
DPG 109	Display Unit	PG0005KJL
DPS 109	Switching Power Pack	PG0008KJL
TIC 002	Level Converter	PT0076KJL
DokuStar Plus	Software for PC data evaluation	PG0012KJL



Kurt J. Lesker Company

1925 Worthington Ave
Clairton, PA 15025

www.Lesker.com